



- ***Owner's Manual***
- ***Assembly Instructions***
- ***Warranty Information***

**Manufacturer: Protective Enclosures Company**

277 Douglas Avenue, Suite 1012

Altamonte Springs, Fl. 32714

1-800-331-2628

info@protectiveenclosures.com

[www.thetvshield.com](http://www.thetvshield.com)

*Save this assembly manual for future reference in the event that you need to order replacement parts.*



## CAUTION:

PROTECTIVE ENCLOSURES COMPANY LLC (PEC) DOES NOT WARRANT AGAINST DAMAGE CAUSED BY THE USE OF ANY PEC PRODUCT FOR PURPOSES OTHER THAN THOSE FOR WHICH IT WAS DESIGNED OR DAMAGE CAUSED BY UNAUTHORIZED ATTACHMENTS OR MODIFICATIONS, AND IS NOT RESPONSIBLE FOR ANY DAMAGES, CLAIMS, DEMANDS, SUITS, ACTIONS OR CAUSES OF ACTION OF WHATEVER KIND RESULTING FROM, ARISING OUT OF OR IN ANY MANNER RELATING TO ANY SUCH USE, ATTACHMENTS OR MODIFICATIONS.

- Prior to installation of this product, the installation instructions should be read and completely understood. The installation instructions must be read to prevent personal injury and property damage. Keep these installation instructions in an easily accessible location for future reference.
- The ground structure must be capable of supporting at least four times the maximum load capacity. If not, the ground structure must be reinforced.
- Do not install the kiosk near heaters, fireplaces, air conditioning or any other heat producing source. Failure to do so may result in damage to the display and could increase the risk of fire.
- Make sure no water or natural gas lines are present where the kiosk is to be installed. Cutting or drilling into water or natural gas lines could cause personal injury or property damage.
- When mounting the kiosk to concrete or any other ground covering, it is recommended that a minimum of 3" anchoring hardware is used.
- Proper installation procedure by yourself or a qualified service technician, as outlined in the installation instructions, must be adhered to. Failure to do so could result in serious personal injury.
- It is recommended that two or more people perform the installation. Injury and/or damage can result from dropping or mishandling the enclosure.
- If you don't understand these installation instructions, please consult an installation specialist.

BE SURE TO COMPARE YOUR TV DIMENSIONS TO THE MAXIMUM INTERIOR DIMENSIONS OF THE TV SHIELD PRO KIOSK. IF YOUR TV OR DISPLAY IS TOO LARGE IT WILL NOT ALLOW FOR PROPER INSTALLATION OR USE.

## DIMENSIONS:

**THE TV SHIELD PRO® KIOSK 30-32"**  
FITS MOST 30" TO 32" TVS  
MAX INTERIOR DIMENSIONS: 18.5"W X 30.6"H X 3.65D  
EXTERIOR DIMENSIONS: 20.5"W X 69.75"H X 10"D

## **TOOLS REQUIRED FOR INSTALLATION**

*These are the tools that are generally required for assembly of our products. These tools are not included with the product purchase, nor included in the box. You will need to use a separately sold TV wall or ceiling mount.*

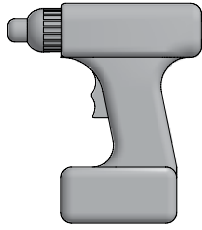

***Cordless Drill or Electric Drill***



***5/16" Socket and Socket Wrench***

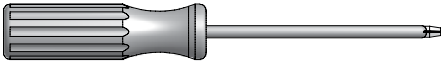

***Phillips Screw Driver***



***Socket specifically for the customer provided concrete anchors in step 2***



***Drill bit specifically for the customer provided concrete anchors in step 2***

# **PARTS IDENTIFICATION**

## ***Included in Box***



***Front Frame x 1***

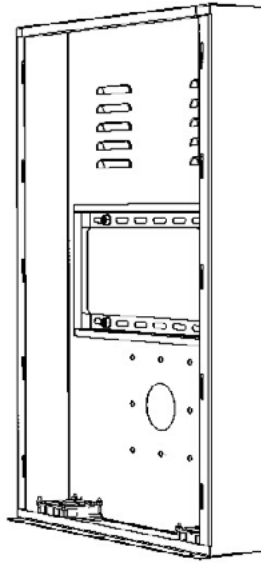

***Back Housing x 1***



***Internal Mount Brackets x 2***

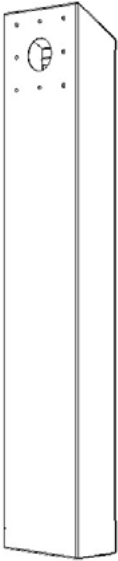

***Pedestal x 1***



***Key x 1***

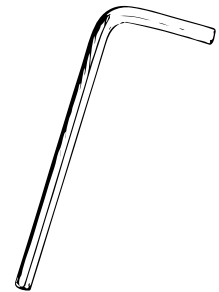

***T-27 Security Screw L-Key x 1***

*See Remaining Parts Identification Items on the Next Page*

# PARTS IDENTIFICATION

## Included in Box

### TV Screws

M4x12mm

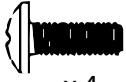

x 4

M4x30mm

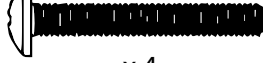

x 4

M6x12mm



x 4

M6x35mm

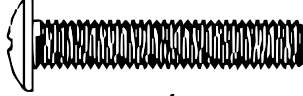

x 4

M8x25mm

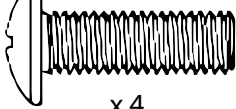

x 4

M8x45mm

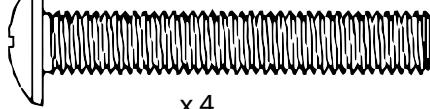

x 4

### Spacers

M6x17mm

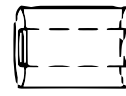

x 4

M8x22mm

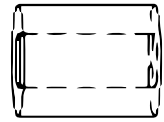

x 4

10mm



i x 4

2.5mm



x 4

### Washers

M4



x 4

M6



x 4

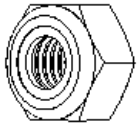

5/16 Nylon Lock Nut x 8

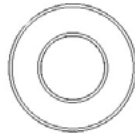

5/16 Washer x 8

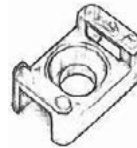

Zip Tie Bases x 6

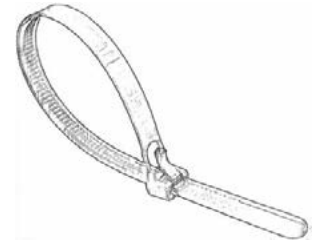

Zip Ties x 6

## STEP 1: Install Kiosk Stand

*\*Read all of the assembly notes, caution notices, and important information prior to starting the installation.*

1. Remove the access panel from the stand by unlocking the panel and shifting out and up.
2. Place the stand in the desired location and mark the 4 holes for anchoring. The cutout at the bottom of the stand is to run your stub out for cable entry. If your application does not have power or other cabling as a stub out, you can drill through the stand and run conduit. We recommend using watertight conduit connectors or you must use rust prevention on the exposed edges where the hole was drilled.
3. Install the customer provided anchoring hardware per the specific instructions for the anchors used. The holes in the stand are 5/16" diameter and it is recommended to use 1/2 " anchoring hardware.

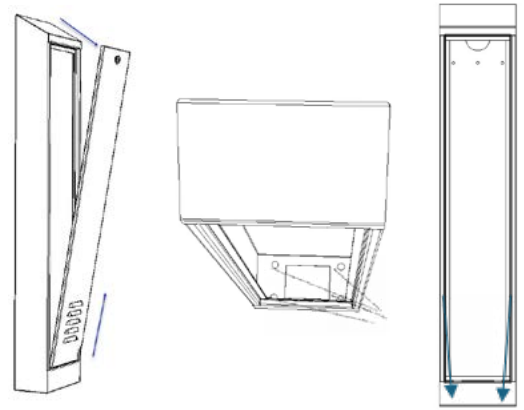

## STEP 2: Remove Front Frame from Base of the Enclosure

1. Use the supplied T-27 torx L-Key to remove the security screws in the front frame.
2. Shift the front frame up and forward to remove from the base.

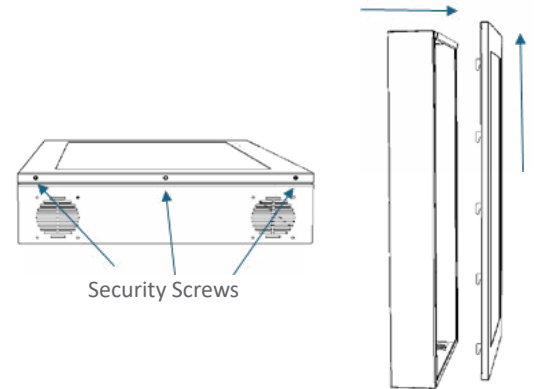

## STEP 3: Connect the Enclosure Base to the Stand

1. Align the threaded studs on base with holes in the stand.
2. Install the 5/16" washers and 5/16" nylon lock nuts. Tighten.

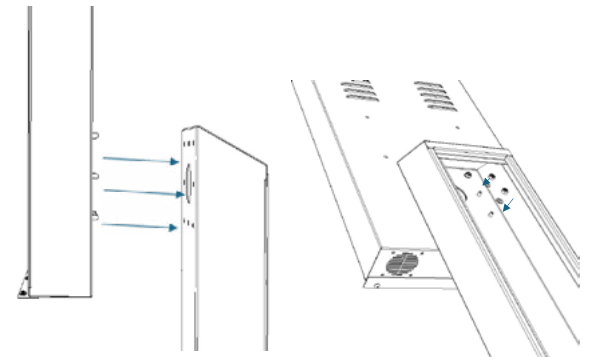

## STEP 4: Connect Vertical Mount Brackets to TV

1. Install the vertical TV mounting brackets using the supplied M4, M6, or M8 screws.

**NOTE:** If your TV has an offset mounting hole position please use the supplied spacers to ensure the vertical arms are level.

**NOTE:** If you would like to move the TV closer to the front glass, you can install the provided spacers between the TV and the vertical arms and use the longer screws.

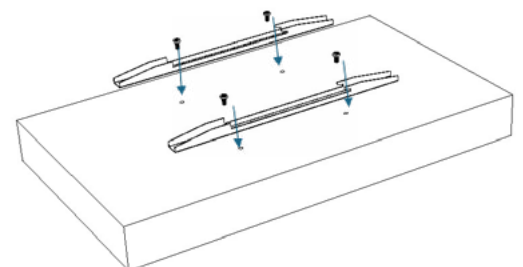

## STEP 5: Run Power/Other and Connect TV to Internal Mount

1. Run the Fan Power Cord, TV power cord, and any other wiring needed through the cable pass and into stand.
2. Lift the TV up and connect power cord and other wiring as needed.
3. Hook the top vertical brackets on the top flange of the internal mount.
4. Pull down on the locking strap to allow the lock to engage past the bottom flange of the internal mount.

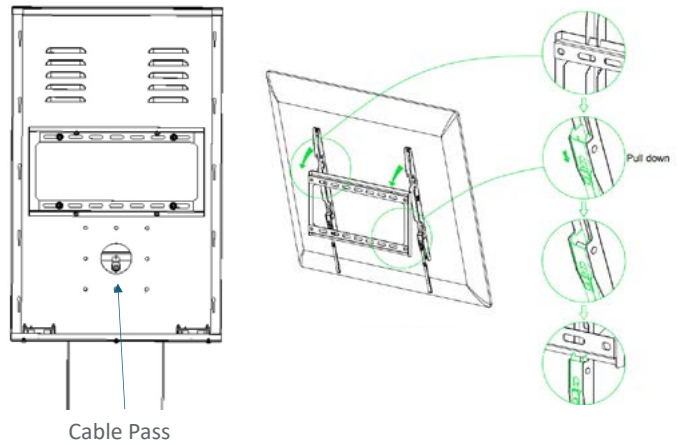

## STEP 6: Install Front Frame

1. Place the front frame against enclosure base approximately  $\frac{3}{4}$ " higher than the base and shift down. This will allow the front frame to hook onto the top flange and for tab alignment.
2. Shift down applying force to the top of the enclosure and compressing the seal.
3. Install security screws using the supplied T-27 L-Key

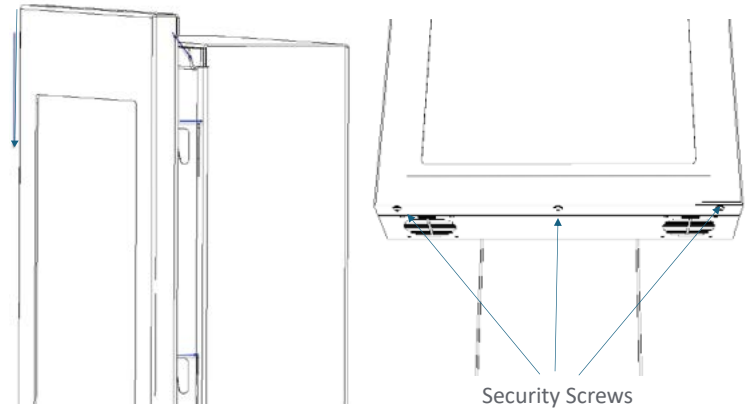

## STEP 7: Install Power Strip, Peripheral Devices, and Stand Access Panel

1. Install power strip and any peripheral devices in the stand using the supplied zip tie busses and zip ties.
2. Re-install the stand access panel by hooking at the bottom, shifting forward, and locking.

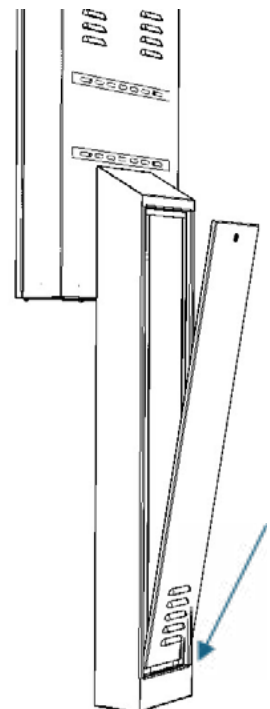

# MORE PRODUCTS

## PEC's Indoor & Outdoor TV & Display Enclosure Solutions



### ENCLOSURES GUIDE

All Protective Enclosures Company TV and display enclosures offer high impact resistance, shatterproof front panels (anti-glare available for some units), security systems, theft, burglary, vandalism, and tampering protection, and cable pass-throughs.

TV Shield	Display Shield	TV Shield	TV Shield Portrait	TV Shield Lite	TV Shield E-Series
TV/Display Access Style: Hinged Shatterproof Front Panel Props Open with Prop Arms (Front Panel Cannot be Detached)	TV/Display Access Style: Shatterproof Front Panel can be Detached by Removing the Security Screw System	TV/Display Access Style: Shatterproof Front Panel is Secured in the Front Frame which Props Open with Gas Shocks (Front Panel and Frame Cannot be Detached)	TV/Display Access Style: Shatterproof Front Panel is Secured in the Front Frame which can be Detached by Removing the Security Screw System	TV/Display Access Style: Shatterproof Front Panel is Secured in the Front Frame which can be Detached by Removing the Security Screw System	TV/Display Access Style: Robust Opaque Front Cover can be Detached and Stored on Hooks at the Bottom of the Back Housing
Includes Back Housing which Attaches to the Wall with Separately Sold VESA Mount	Includes Back Housing which Attaches to the Wall with Separately Sold VESA Mount	Includes Back Housing which Attaches to the Wall with Separately Sold VESA Mount	Includes Back Housing which Attaches to the Wall with Separately Sold VESA Mount	Includes Back Frame (Not Housing) which Mounts Directly to the Wall	Includes Back Housing which Flush Mounts to the Wall
Sizes Ranges: 19-65"	Sizes Ranges 19-65"	Sizes Ranges: 40-85"	Sizes Ranges 40-65"	Sizes: 44-85"+	Sizes Ranges: 36-65"
HMWPE Polymer Landscape Anti-Glare (Available) Key Lock(s) Security System 3-Year Warranty Filtered Ventilation, Weatherproof, Water, Moisture, Dust, Salt Water Air/Corrosion, and Pest Resistant	HMWPE Polymer Portrait or Landscape (Sold Separately) Anti-Glare (Available) Security Screw System 7-Year Warranty Filtered Ventilation, Weatherproof, Water, Moisture, Dust, Salt Water Air/Corrosion, and Pest Resistant	Powder Coated Aluminum/Steel Landscape Anti-Glare (Standard) Key Lock(s) Security System 5-Year Warranty Filtered Ventilation, Weatherproof, Water, Moisture, Dust, Salt Water Air/Corrosion, and Pest Resistant	Powder Coated Steel Portrait Anti-Glare (Standard) Security Screw System 5-Year Warranty Filtered Ventilation, Weatherproof, Water, Moisture, Dust, Salt Water Air/Corrosion, and Pest Resistant	Powder Coated Aluminum Portrait or Landscape (Landscape can be Installed Portrait Orientation) Anti-Glare (Available) Security Screw System 5-Year Warranty Dust, Salt Water Air/Corrosion, and Pest Resistant	ABS and ASA Polymer Landscape Opaque Removable Front Cover Anti-Theft Locking Holes 2-Year Warranty Weatherproof, Water, Moisture, Dust, Salt Water Air/Corrosion, and Pest Resistant

\* ANTI-LIGATURE IS AVAILABLE \*

This guide was last updated 4/28/23. Details and prices are subject to change and may have been updated since this chart was created.

#### PROTECTION & FEATURE OPTIONS

From weatherproof, tamper-resistance, shatterproof screen protection, water-resistance, temperature regulation, and UV defense to pest-control and more, we protect TVs and displays from almost any threat.



#### TOUCH SCREEN ENCLOSURES

Enjoy TV and display protection plus touch screen capabilities. Ask us about our interactive touchscreen capable TV enclosure solutions.



#### ANTI-LIGATURE ENCLOSURES

Our sloped top TV enclosure solution is designed to be used in environments where anti-ligature requirements are in place to prevent intentional or accidental self-harm to patients or others.





## **The TV Shield PRO Kiosk® Limited Product Warranty**

This limited warranty is provided by Protective Enclosures Company, LLC for The TV Shield PRO® Kiosk product(s) identified by the purchaser's registration as indicated below. This limited warranty is between Protective Enclosures Company, LLC and the registered purchaser of the product. There are no other warranties, express or implied, except as required by law, including warranties of merchantability and fitness for a particular purpose, that are provided for herein; however, all such implied warranties, if any, are limited to the duration of this specific limited product warranty. Some states do not allow limitations on how long an implied warranty lasts, so the above limitations may not apply to you.

### **The TV Shield PRO Portrait® Limited Product Warranty:**

\* 2 Year Limited Warranty on product failure or quality of workmanship and on all components against any manufactures defects.

This is a limited warranty, subject to the conditions, limitations and exclusions identified herein. Protective Enclosures Company, LLC warrants to the original purchaser of the registered or identified product for a period of time listed above, from the date of purchase, that the product shall be free of defects in materials, and workmanship, and subject to the limitations set forth below; Protective Enclosures Company, LLC will repair or replace, at its option, any defective unit. Protective Enclosures Company, LLC hereby warrants to the original retail purchaser of this product that should this product or any part thereof, under normal use and conditions, prove to be defective in material or workmanship within the time frame from the original purchase specified above, such defect(s) will be repaired or replaced with a new or reconditioned product (Protective Enclosures Company LLC's option) without charge for parts and repair labor. Purchaser must return the product to Protective Enclosures Company, LLC, (return receipt requested) or by other means that confirms delivery and Protective Enclosures Company, LLC shall make the said repairs or replacement within 60 days of receipt. In some instances the product may have been discontinued and cannot be replaced, or repaired. In that instance Protective Enclosures Company, LLC shall in its discretion attempt to replace the product with a substantially similar product in a current model or design or pay the purchaser a sum for the then fair market value of the product, considering the amount of depreciation since sale, and the use of the product. This Limited Warranty is the original retail purchaser's sole remedy for any and all such defect(s).

### **Conditions and Limitations:**

Proof of purchase is required (i.e. the sales receipt or other proof of payment). Damage caused by accidents, abuse, misuse or modification of the product will render this warranty null and void. This warranty is applicable only to the original purchaser and is not assignable or transferable. To obtain repairs or replacement under the terms of this warranty, please contact Protective Enclosures Company, LLC at 1-800-331-2628 or visit [www.protectiveenclosures.com](http://www.protectiveenclosures.com). You will need to provide proof of purchase (dated receipt showing where the item was purchased) and the product part number in order to receive warranty service. The purchaser is required to send the product back to Protective Enclosures Company or to a designated repair center and the purchaser is responsible for all charges for shipping and handling.

**This Limited Warranty does NOT cover:**

1. Products which have been subject to abuse, accident, alteration, modification, tampering, negligence, misuse, theft or attempted theft, vandalism, improper installation, lack of reasonable care, unauthorized repair or service, or if the model or serial number has been altered, tampered with, defaced or removed.
2. Loss or damage caused by the use of unauthorized cleaning products or methods that damage or destroy the product.
3. Initial installation or the removal and re-installation of the product.
4. Cosmetic damage, an act of God, or natural disaster.
5. Products modified or used for any purposes other than for those which the product is specifically designed.
6. Damage that occurs in shipment (the third party shipping service is responsible for any shipping damages).

**The company reserves the right to remedy any minor defects in defective units by replacing defective, inoperable or missing parts rather than offering a refund or exchange.**

Protective Enclosures Company, LLC, or any subsidiaries, shall not be liable, under any circumstances, for incidental, indirect, special, and consequential or multiple damages as a result of the sale or use of this The TV Shield *PRO*® product. Some states and countries do not allow the exclusion or limitation of incidental or consequential damages, so the above limitations or exclusions may not apply to you.

THE EXTENT OF PROTECTIVE ENCLOSURES COMPANY, LLC'S LIABILITY UNDER THIS WARRANTY IS LIMITED AS PROVIDED ABOVE AND, IN NO EVENT, SHALL THE LIABILITY OF PROTECTIVE ENCLOSURES COMPANY, LLC EXCEED THE PURCHASE PRICE PAID BY THE ORIGINAL RETAIL PURCHASER FOR THE PRODUCT.

**Any questions regarding this warranty should be addressed to:**

Protective Enclosures Company, LLC  
The TV Shield | The Display Shield | The TV Shield *PRO* | The TV Shield *PRO* Lite  
ATTN: WARRANTY DEPARTMENT  
277 Douglas Avenue, Suite 1012  
Altamonte Springs, Fl. 32714  
USA  
800-331-2628 Toll Free

THIS WARRANTY IS IN LIEU OF ALL OTHER EXPRESS WARRANTIES OR LIABILITIES. ANY IMPLIED WARRANTIES, INCLUDING ANY IMPLIED WARRANTY OF MERCHANTABILITY, SHALL BE LIMITED TO THE DURATION OF THIS WRITTEN WARRANTY. IN NO EVENT SHALL PROTECTIVE ENCLOSURES COMPANY, LLC, OR ANY SUBSIDIARY, OWNER, OR PARTNER BE LIABLE FOR ANY CONSEQUENTIAL OR INCIDENTAL DAMAGES FOR BREACH OF THIS OR ANY OTHER WARRANTY EXPRESS OR IMPLIED WHATSOEVER.

No person or representative is authorized to assume for Protective Enclosures Company, LLC any liability other than expressed herein in connection with the sale of this product. Some jurisdictions do not allow limitations on how long an implied warranty lasts or the exclusion or limitation of incidental or consequential damages so the above limitations or exclusions may not apply to you. This warranty gives you specific legal rights and you may also have other rights, which vary from jurisdiction to jurisdiction.

## **REFUND/RETURN POLICY**

We offer a **30 Day Money Back Guarantee** on all unopened, unused and/or undamaged units. The unit must be unaltered and it must have the protective covering(s) on the front panel and be undamaged and in original new condition. A 10% restocking fee applies and all refunds will be minus the actual shipping charges to and from Protective Enclosures Company.

**Upon acceptance and processing of the return/refund, all funds will be returned to the original method of payment (minus all fees).**

**All refunds will be returned to the original method of payment minus all fees and will be processed on our end within 10 business days (excluding weekends and holidays).**

Protective Enclosures Company DOES NOT accept returns on units that have been drilled, scratched, damaged, abused or have had the protective coverings taken off of the front panel, as they cannot be resold as new products. If you have made a mistake when drilling or mounting The TV Shield *PRO*<sup>®</sup>, although we will not accept a return within terms, we do have several remedies available to you to help you repair the “damaged” area and still be able to use your unit. Please call our customer service department for help at 1-800-331-2628 which is toll free, anytime during normal business hours which are between 9:30am and 6:00pm Eastern Standard Time, Monday through Friday.

### **LIMITED WARRANTY**

**Protective Enclosures Company, LLC – The TV Shield *PRO*<sup>®</sup> Limited Warranty – Valid in the United States and Canada**

#### **Protective Enclosures Company, LLC**

The TV Shield | The Display Shield | The TV Shield *PRO* | The TV Shield *PRO* Lite  
277 Douglas Avenue, Suite 1012  
Altamonte Springs, Fl. 32714  
800-331-2628 Toll Free

Specifications are subject to change without notice.  
All trademarks are the property of their respective owners.  
[www.protectiveenclosures.com](http://www.protectiveenclosures.com)



**Protective Enclosures Company**

277 Douglas Avenue, Suite 1012

Altamonte Springs, Fl. 32714

1-800-331-2628

Specifications are subject to change without notice.  
All trademarks are the property of their respective owners.  
*Copyright (©) Protective Enclosures Company, LLC*

**[www.thetvshield.com](http://www.thetvshield.com)**